

PART NUMBER	LEAD FREE VERSION	MARKING
7432E0525S01	7432E0525S01LF	YES

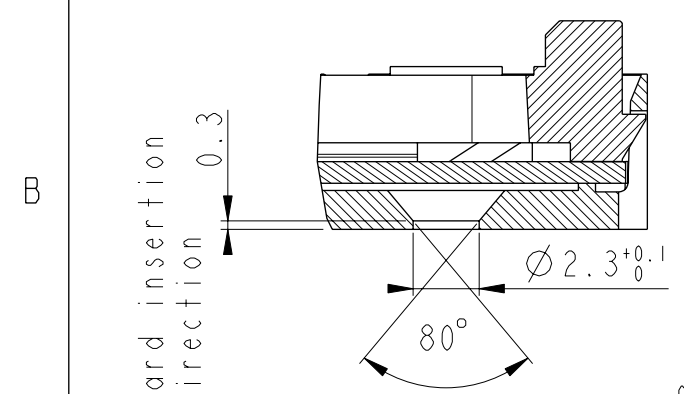

SECTION X-X
SCALE 4:1

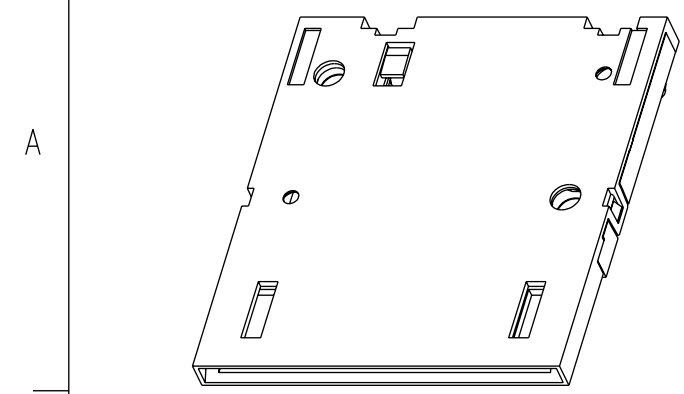
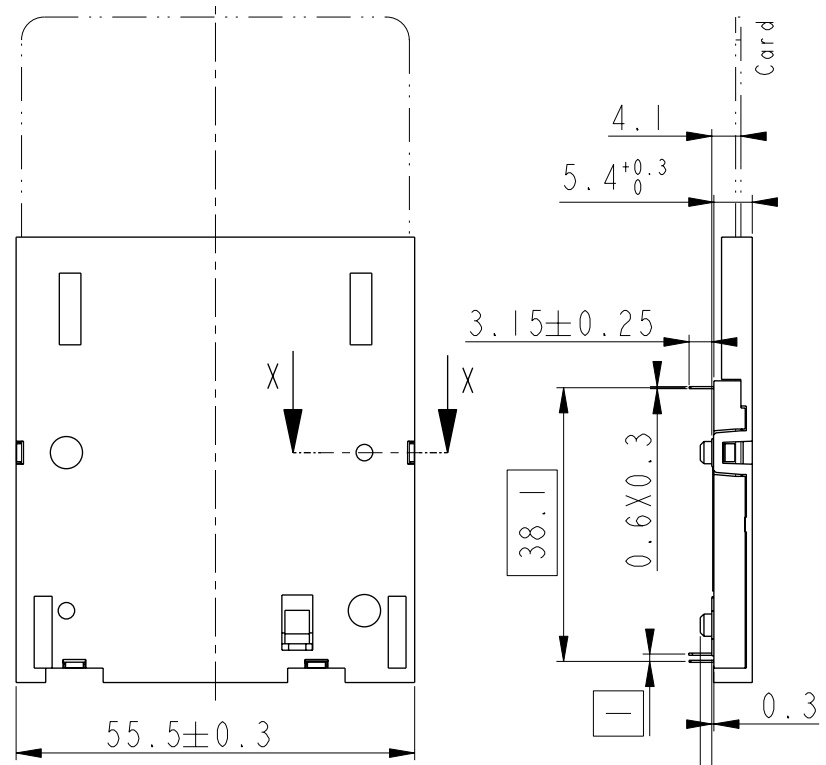

GENERAL :
High cycle life duration smart card connector with landing type contacts mechanism. The landing type connector also provides the feature of recessed contacts when card is not inserted which protects them against vandalism.
Smart card for reference purposes only.

ELECTRICAL PROPERTIES:
Insulation resistance : > 1000MΩ
Dielectric withstanding voltage : >750 Vrms
Current carrying capacity : Min 10μA, Max 1A
Contact resistance : < 100mΩ

MECHANICAL PROPERTIES :
Operating force : Insertion : F < 10N
Withdrawal : 1 < F < 10N
Contact Normal force : 0.2 < F < 0.3 for 0.6mm of deflection
Durability : 200 000 mating cycles

MATERIAL :
Head reader : High temp. thermoplastic, Colour Black, Rated UL94V0
Cover : Thermoplastic, Rated UL94V0
Contacts : Copper alloy,
Plating : 2.5μm Nickel min. all over
2μm Gold min. on contact area
3μm SnPb(60/40) min. on solder tails (FOR LEADED VERSION)
3μm matte tin min. on solder tails (FOR LEAD FREE VERSION)

ENVIRONMENT :
Operating temperature : -40°C / +85°C
Climatic conditions : UTE 93-421

PACKAGING :
Plastic cavity tray

Recommended PCB Layout
(Component side)

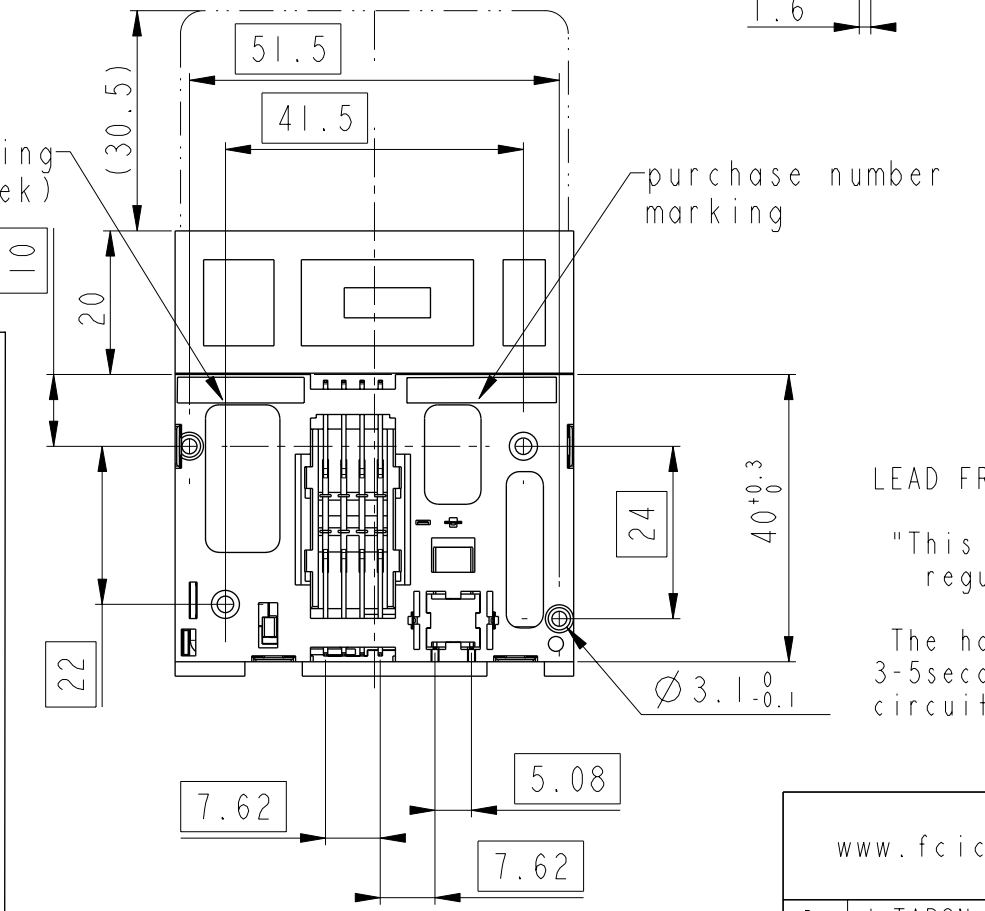
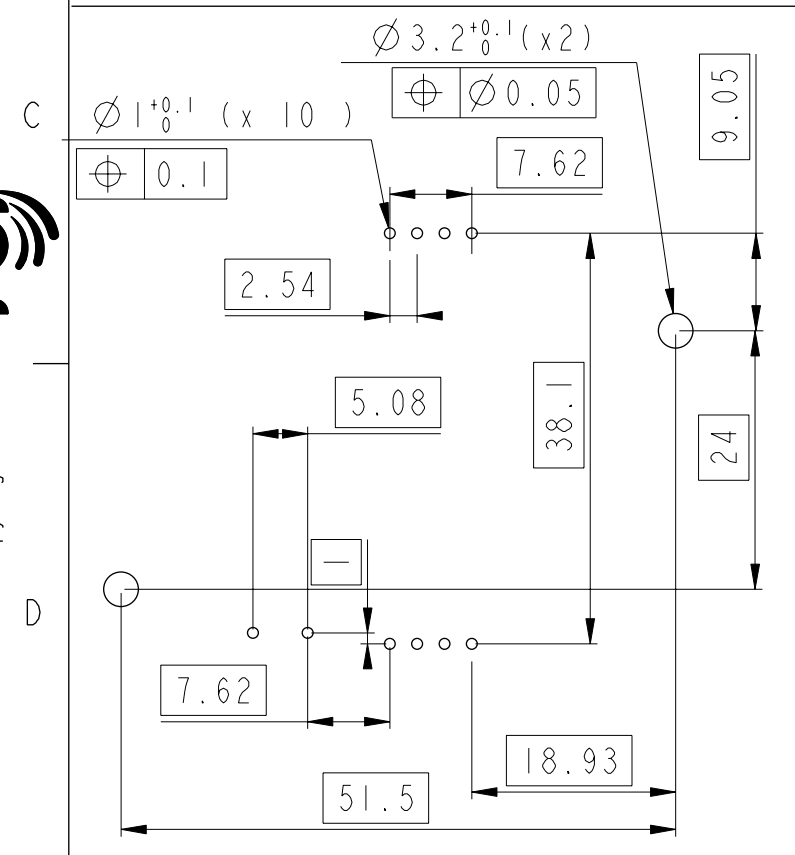

LEAD FREE VERSION:
"This product meets European Union Directives and other country regulations as described in GS-22-008"
The housing will withstand exposure to 260°C peak temperature for 3-5seconds in a wave solder application with a 1.6mm minimum thick circuit board.

General Tolerances

0 to 10mm:	±0.1mm
10 to 30mm:	±0.15mm
30 to 60mm:	±0.2mm
60 and more:	±0.3mm

rev	ecn no	dr	date
A	F20307	DLE	2002/04/29
B	F20341	DLE	2002/06/04
C	LS3088	JTA	2003/11/28
D	I05-0176	NT	2005/09/30
E	I06-0078	DTK	2006/06/19
F	I08-0136	SSC	2008/10/10
-	-	-	-

www.fciconnect.com		surface -- ✓	tolerance std	projection	mm
		ISO 1302	ISO 406 ISO 1101		Scale 1:1
		TOLERANCES UNLESS OTHERWISE SPECIFIED		size A3	ECN 108-0136
Dr	J. TARON	2002/04/29	ANGULAR	0.x ±	Product family MOBILE I/O
Eng	LE GALLIC	2002/04/29	LINEAR	0.xx ±	Spec ref --
Chr	S.S.CHERIAN	2008/10/10	0° ±	0.xxx ±	
Appr	S.S.CHERIAN	2008/10/10	Product family MOBILE I/O		
		title E05 WITH PEG		Rev. F	
		SMART CARD READER VXX 27787		VJW54006	
catalog no		See Table	CUSTOMER		sheet 1 of 1

Copyright FCI.